

# INSTALLATION INSTRUCTIONS

## VERTICAL CABLE RAILING

### 36" SYSTEM WITH 3" ALUMINUM POSTS

#### ITEMS REQUIRED FOR INSTALLATION

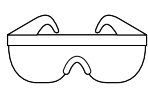

SAFETY GLASSES

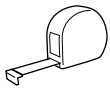

TAPE MEASURE

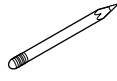

PENCIL

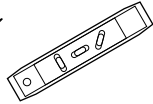

LEVEL

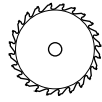

MITER SAW WITH  
NON-FERROUS BLADE

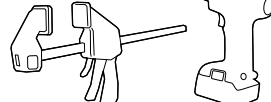

4 CLAMPS



CORDLESS  
DRILL

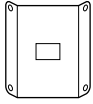

LOWER RAIL  
CLIP JIG



6" #2 SQUARE  
DRIVE BIT



3/16" DRILL BIT



APPROPRIATE FASTENERS  
FOR MOUNTING POSTS TO  
DECK SURFACE

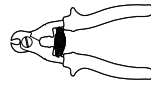

CABLE CUTTING TOOL  
(OPTIONAL)

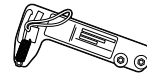

CABLE TENSION GAUGE  
(OPTIONAL)

THESE INSTRUCTIONS COVER INSTALLATION OF A VERTICAL CABLE RAILING SYSTEM. PLEASE VISIT MANUFACTURER'S WEBSITE FOR OTHER RAILING SYSTEMS.

#### IMPORTANT NOTES:

- Do not install base plate covers until railing assembly is completed.
- Actual 6' cable panel size = 69.43".
- 3" posts are required to reach 6' lengths.

**CAUTION! IF INSTALLING LIGHTING, WIRING MUST BE INSTALLED PRIOR TO SECURING POSTS TO DECK SURFACE AND INSTALLING TOP RAIL SNAPS.**

It is the responsibility of the installer to meet all local code requirements and obtain all required building permits. The installer should determine and implement appropriate installation techniques for each installation situation. The manufacturer or its reseller shall not be held responsible for improper or unsafe installation.

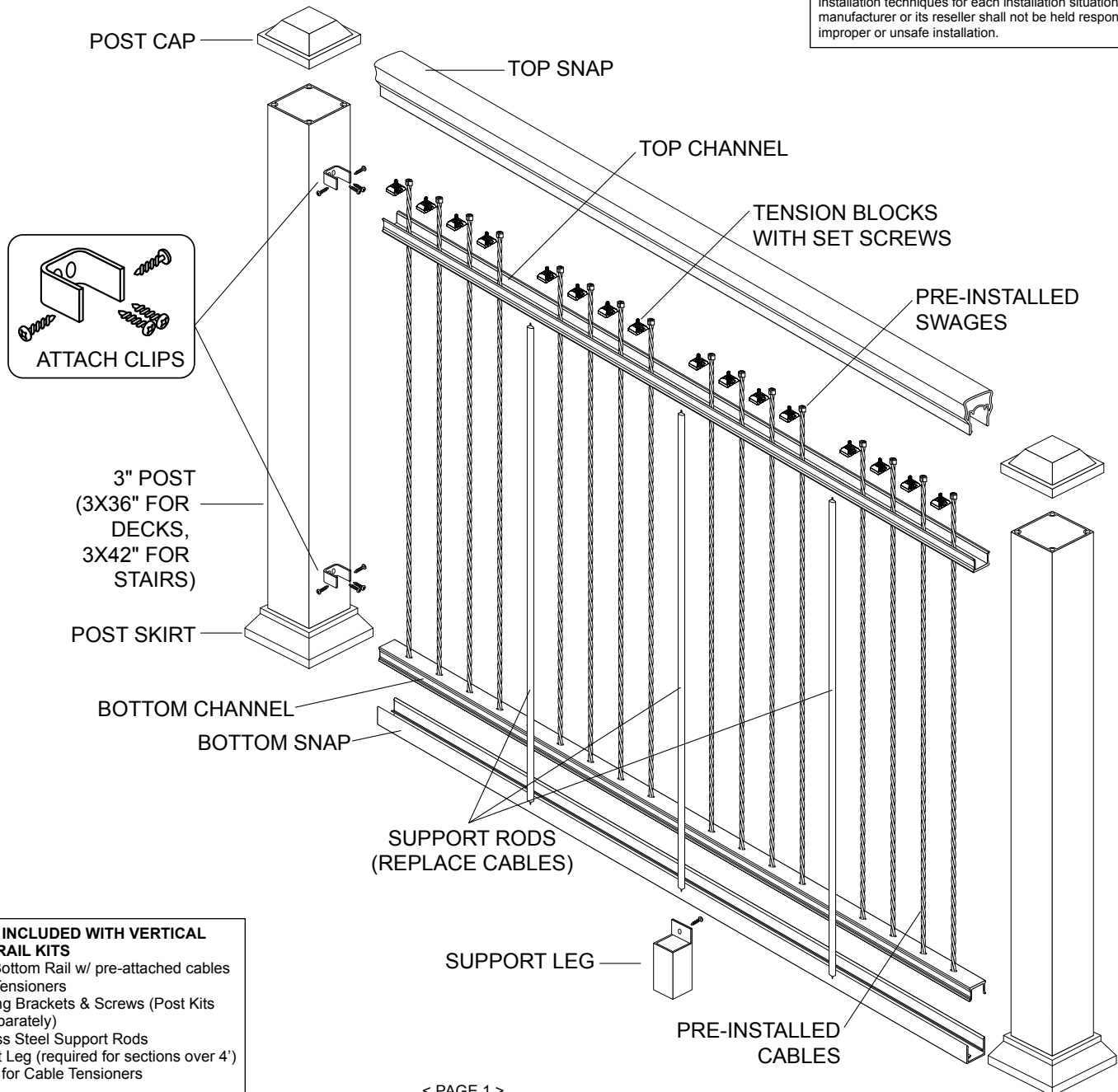

#### WHAT'S INCLUDED WITH VERTICAL CABLE RAIL KITS

- Top & Bottom Rail w/ pre-attached cables
- Cable Tensioners
- Mounting Brackets & Screws (Post Kits sold separately)
- Stainless Steel Support Rods
- Support Leg (required for sections over 4')
- Hex Bit for Cable Tensioners

# 3" ALUMINUM POST INSTALLATION

## 1 Determine Post Configurations and Locations (i.e. end, center, corner, etc.) Dia. #1

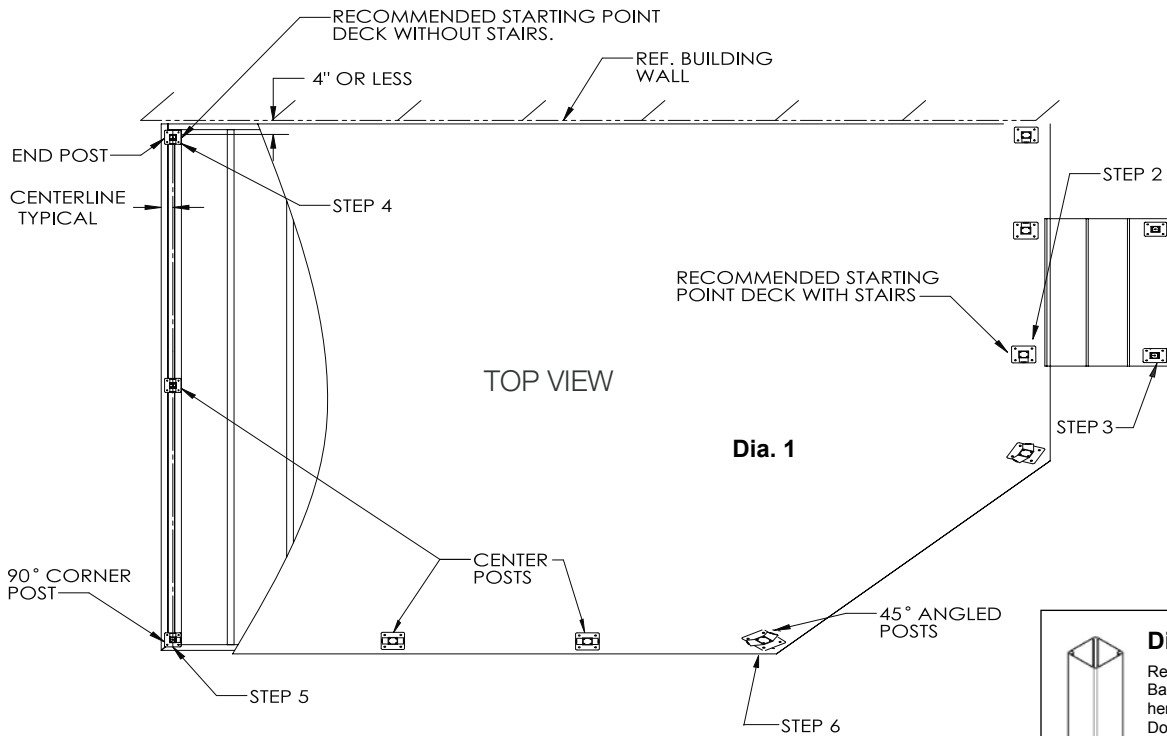

## 2 Prepare Posts (end, center or corner)

- Using the lower clip jig included with the post kits, install lower clip on post and secure with (2) - #8x3/4" self-tapping screws (Dia. 2). Clips are located in the Panel Kit

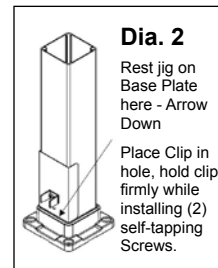

**POST-TO-SURFACE MOUNTING SCREWS:**

3" Posts – Residential Deck Applications – 5/16" X 6" Exterior Torx/Star Drive Construction Screws

3" Posts – Commercial Deck Applications – 3/8" X 6" Exterior Torx/Star Drive Construction Screws

3" Posts – Residential Concrete Applications – Tapcon® 5/16" x 3" Hex Washer Head Concrete Anchor

## 3 How to Secure Posts to Deck

Install proper post blocking as per (Dia. 3). Use proper attachment screws or anchors as directed. (Deck screws at each post location, are not included with kits).

- With 3/16" drill bit, pre-drill through deck boards and into blocking
- Drill a 5/8" hole in center of four deck screw holes for lighting wires (optional)
- Level and plumb post using shims
- Secure posts to deck with suggested screws

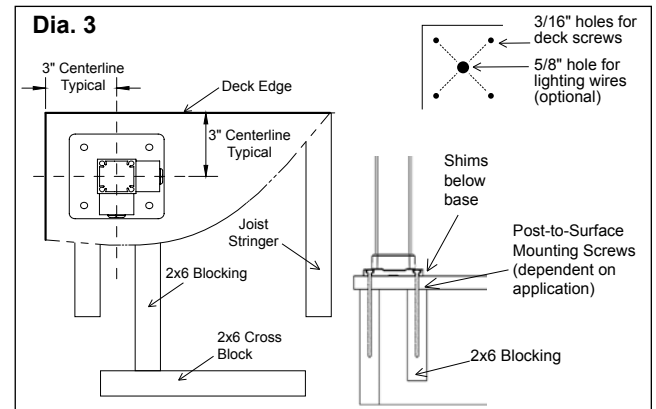

## 4 Installation of Stair End Posts (If applicable)

- Temporarily install end stair post so rail centerline aligns with top stair posts installed in Step 1 (if applicable). Recommended post installation locations are as shown (Dia. 4)
- Return to completing deck railing installation; upon completion of deck railing, refer to stair railing installation instructions.
- Secure posts to deck with suggested screws

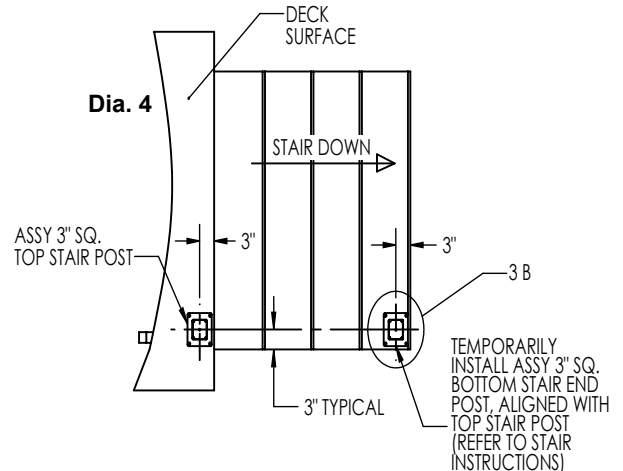

### 5 Installation of 90-degree Corner Posts

Position post on same 3" centerline (typical) and temporarily fasten using a single fastener through base plate mounting hole. (Dia. 5)

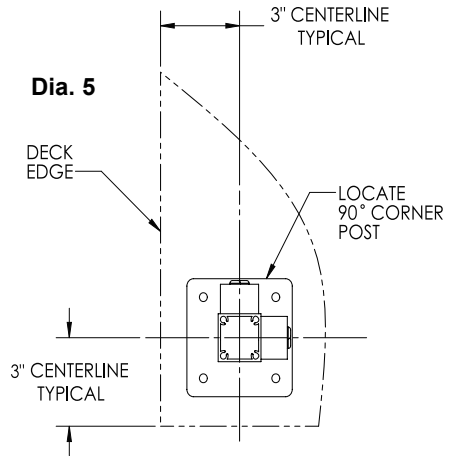

### 6 Installation of End Posts

Install posts at all end locations with maximum gap between post and wall to be less than a 4" opening. (Dia. 6)

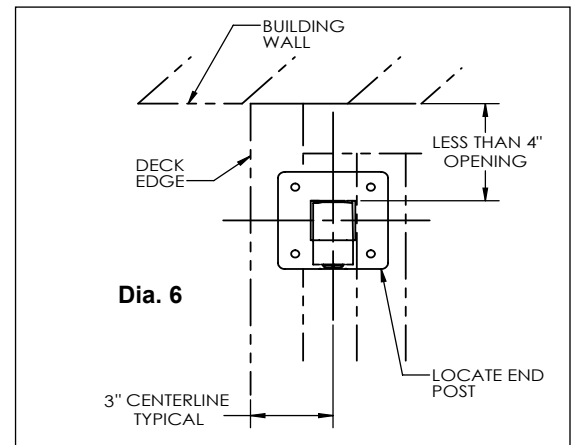

### 7 Installation of 45-degree corner posts

Position post on same 3" centerline (typical) and temporarily fasten to deck surface. Use one 22.5° Panel Attach Kit (purchased separately) to install 45 degree corner posts. (Dia. 7)

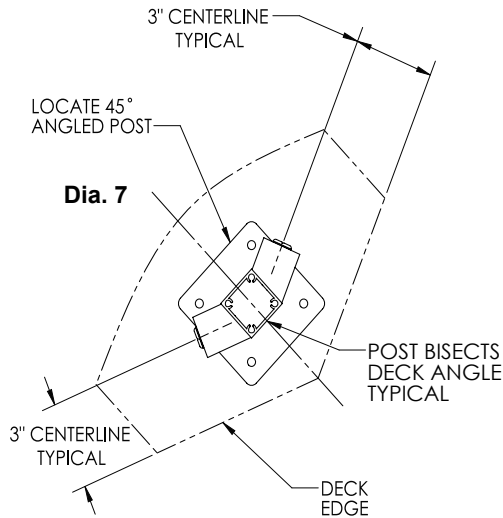

### 8 Determine Center Post Locations

Loosely lay center post over deck edge and adjust as required to determine final center post mounting locations. (See Dia. 8 & 9)

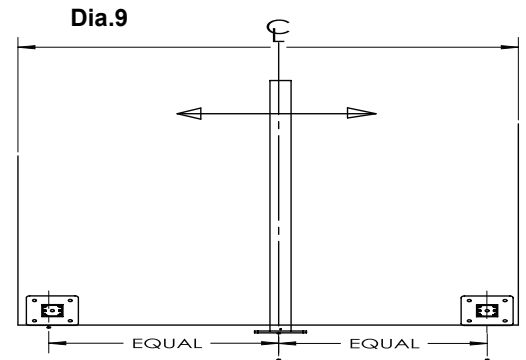
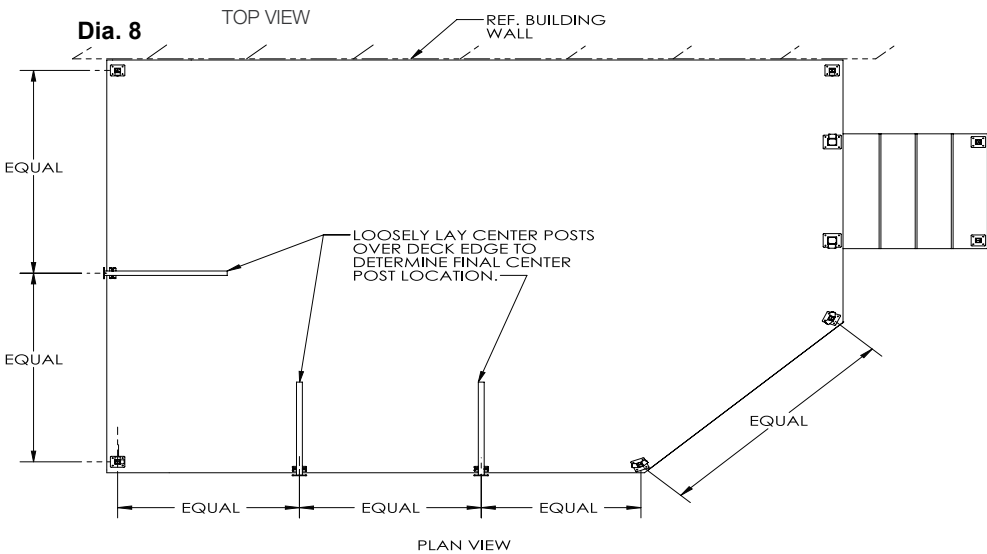

# DECK PANEL INSTALLATION

**IMPORTANT NOTE:** See Post Installation Instructions before proceeding to Deck Panel Installation.

## 1 Prep Rail & Cable Section

Remove cable panel from packaging and lay section flat on a non-abrasive surface. Spread U-Channels until cables are tight. (Dia 1). **Note:** Do not install tensioning blocks until instructed.

## 2 Cut/Remove Cables for Support Rod Installation

- Clamp or hold panel against installed posts, adjust for equal end spacing. (Dia. 2). Center panel so there is equal distance from post to first cable on each end
- As per chart below, determine the necessary number of support rods required. The support rods should be spaced with no more than 4 cables between rods

Required Support Rods (evenly spaced)	Length of Section
1	19" to 38"
2	39" to 57"
3	58" to 76"

- Cut and remove cables where rods will be installed. **Note:** Use appropriate Stainless Cable Cutting Tool
- Mark the top and bottom rails at four (4) locations
- Unclamp panel from posts

## 3 Cut Panels to Length

- Cut bottom channel and top channel 1/16" less than opening size. **CAUTION:** Ensure there are no cables in cutting path
- Clean cut areas and apply touch-up paint on exposed ends

## 4 Insert Support Rods

- Slide top channel up until the swages stop the top channel
- Insert support rods into holes at cut cable location(s) and slide top channel down to hold them in place.

## 5 Secure Vertical Cable Rail Panel to Posts

- Scribe a line horizontally or parallel from the top edge of the post approximately 3-13/16" down from the top edge. Then scribe a line vertically in the center of the post (Dia. 3). This will be used to locate the top rail clip.
- Using (4) - #8x3/4" self-tapping screws, secure the lower two clips to the posts at marked locations
- Slide bottom channel onto lower clips (Dia.4)
- Using (4) - #8x3/4" self-tapping screws, secure the lower two clips to the panel
- Insert clips into top channel of panel on each end
- Align top rail clip edge to the horizontal line scribed into the end post and center.
- Gently push down on upper channel until resting against upper surface of support rods. Secure upper clips to posts using (2) - #8x3/4" self-tapping screws, then secure to the panel using (2) - #8x3/4" self-tapping screws

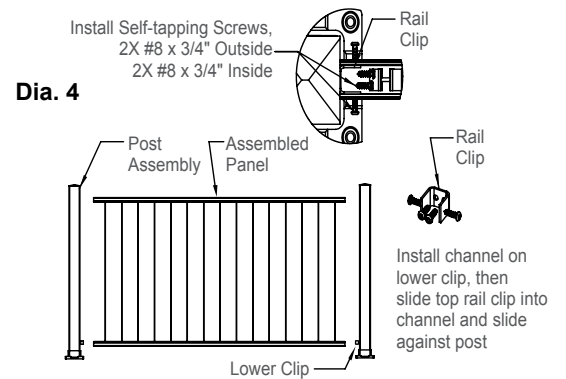
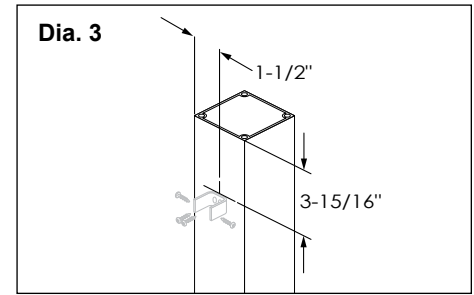
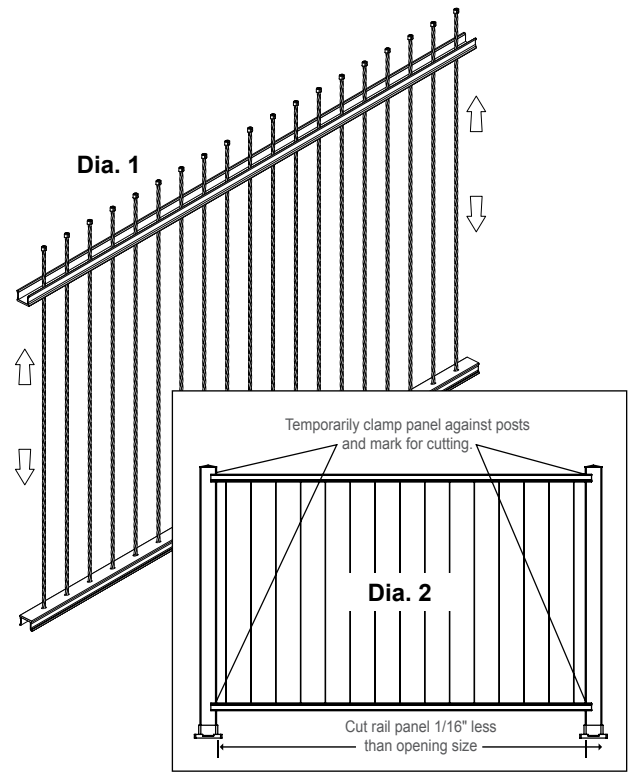

## 6 Tension Cables

- Slide tension blocks between swages and top channel with set screw points facing down (Dia. 5)
- Gently turn set screws just until cable is tight
- Make sure swages and tension blocks don't stick up over the top channel
- **TIP:** Tighten the front set screws first, just until they reach the channel. Then tighten the rear set screws. This helps to keep everything level. (Dia. 6)
- Use included hex bit to tighten tension block set screws in the sequence shown in Dia. 7
- Gradually tighten each tension block in the sequence shown in diagram until cable is straight and not easily bowed. Optional: Use a Loos Cable Tension Gauge to test cables near the center of the cables to reach the appropriate tensions. The recommended range on the PT-1 scale is 15~17 or 137-165 lbs using the Loos Cable Tension Gauge. **CAUTION: DO NOT OVER TIGHTEN SET SCREWS!**

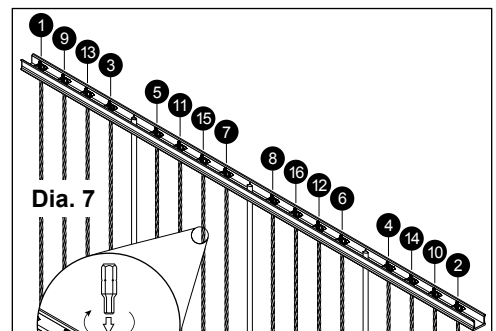
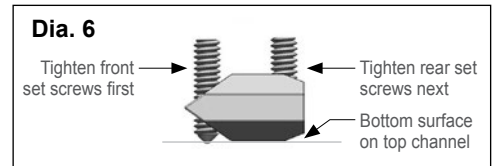
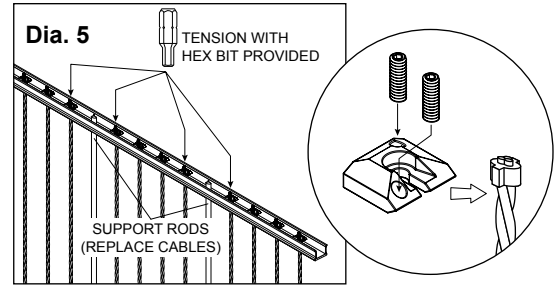

## 7 Cut and Install Bottom Rail Snaps

- Measure between posts at the bottom (Dia. 8)
- Cut bottom snap covers 1/16" less than opening
- Clean cut areas and apply touch-up paint on all exposed metal
- Push rail snaps up under the lower rail channel until properly seated (Dia. 9)

## 8 Install Support Legs

- For openings greater than 4', install a support leg under the center of the bottom rail (Dia. 10)
- Slide support leg under bottom rail and mark
- Install two deck screws at location of support leg, then install support leg over screws
- Using (1) - #8x3/4" self-tapping screw, secure the support leg to bottom rail (Dia. 11)

## 9 Cut and Install Top Rail Snaps

- Measure between posts at the top (Dia. 8)
- Cut top snap covers 1/16" less than opening
- Clean cut areas and apply touch-up paint on all exposed metal
- Push rail snap down onto the top rail channel until properly seated (Dia. 9)
- Install #8 x 1-1/2" self-tapping screws approximately 1-1/2" from the inside of the end posts as shown (both sides). (Dia 12)

## 10 Install Post Caps and Base Plate Covers

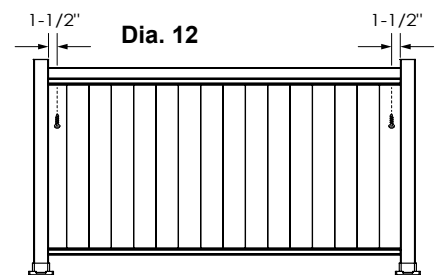
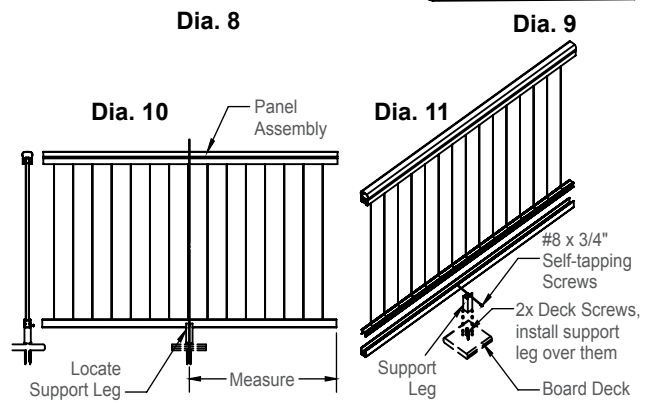
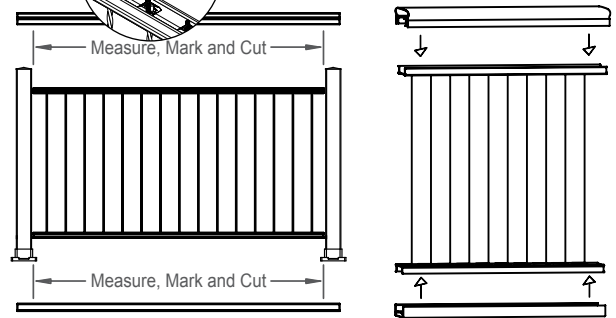

# STAIR PANEL INSTALLATION

**IMPORTANT NOTE:** See Post Installation Instructions before proceeding to Stair Panel Installation.

## 1 Prep Rail & Cable Section

Remove cable panel from packaging and lay section flat on a non-abrasive surface. Spread U-Channels until cables are tight. (Dia 1). **Note:** Do not install tensioning blocks until instructed.

**Important:** Ensure panels are fully extended prior to tensioning cables.

## 2 Cut/Remove Cables for Support Rod Installation

- Clamp or hold panel against installed posts, adjust for equal end spacing. (Dia. 2). Center panel so there is equal distance from post to first cable on each end
- Position stair panel approximately 1 1/2" above stair nosing. TIP: lay a 2x4 board flat on nose of stair treads. This will allow enough room for installation of bottom snap. Clamp stair panel against top and bottom 3" posts. Using a sharp #2 pencil, mark the stair channels at four (4) locations (Dia. 5)
- As per chart below, determine the necessary number of support rods required. The support rods should be spaced with no more than 4 cables between rods

Required Support Rods (evenly spaced)	Length of Section
1	19" to 38"
2	39" to 57"
3	58" to 76"

- Cut and remove cables where rods will be installed. **Note:** Use appropriate Stainless Cable Cutting Tool
- Mark the top and bottom rails at four (4) locations
- Unclamp panel from posts

## 3 Cut Panels to Length

- Cut bottom channel and top channel 1/16" less than opening size. **CAUTION:** Ensure there are no cables in cutting path
- Clean cut areas and apply touch-up paint on exposed ends

## 4 Insert Support Rods

- Slide top channel up until the swages stop the top channel
- Insert support rods into holes at cut cable location(s) and slide top channel down to hold them in place.

## 5 Secure Vertical Cable Rail Panel to Posts

- Using (4) - #8x3/4" self-tapping screws, secure the lower two clips to the posts at marked locations
- Slide bottom channel (channel with angled swages) onto lower clips (Dia. 3)
- Using (4) - #8x3/4" self-tapping screws, secure the lower two clips to the panel
- Insert clips into top channel of panel on each end
- Gently push down on upper channel until resting against upper surface of support rods. Secure upper clips to posts using (2) - #8x3/4" self-tapping screws, then secure to the panel using (2) - #8x3/4" self-tapping screws

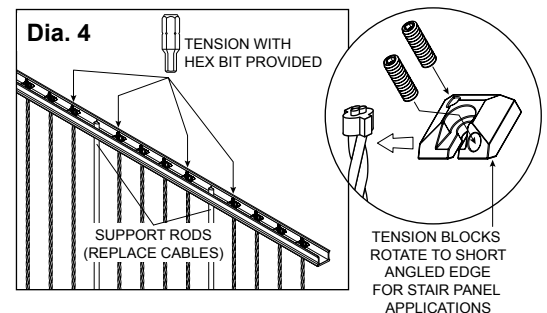
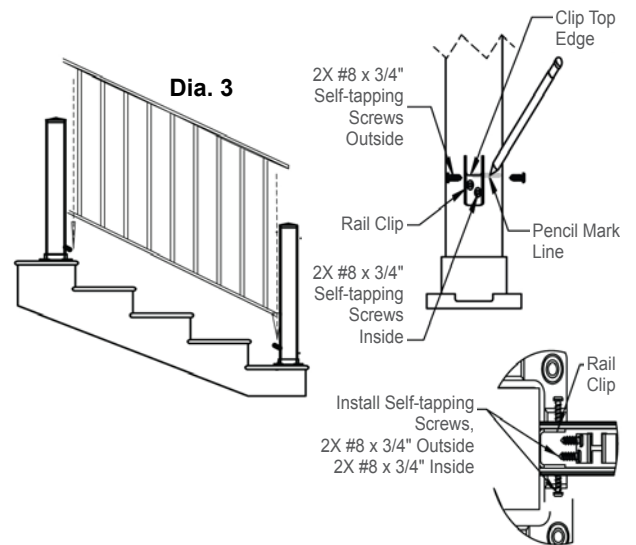
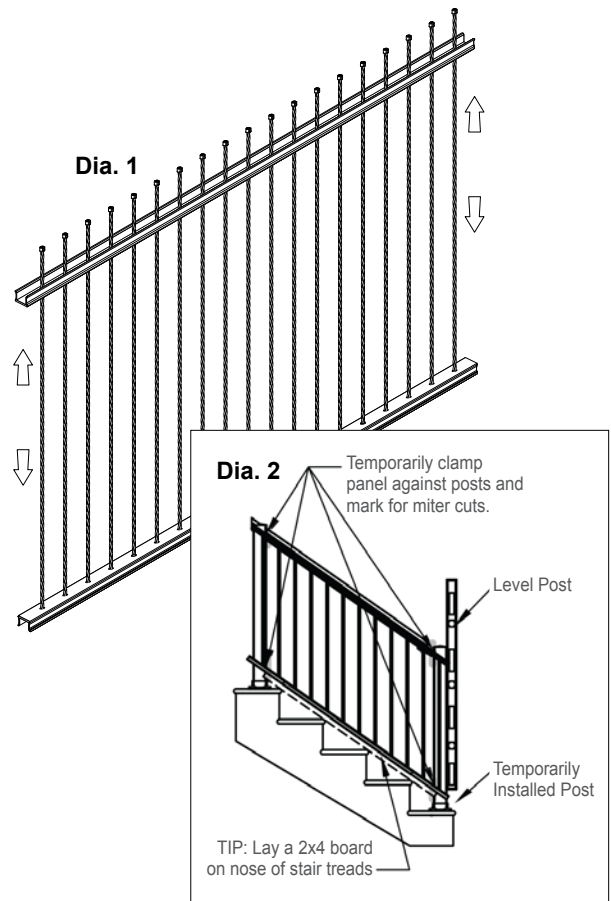

## 6 Tension Cables

- Slide tension blocks between swages and top channel with set screw points facing down (Dia. 4). **Important:** Tension blocks must rotate to short angled surface for stair panel applications. (Dia. 5) **Important:** Rotate angled bottom swages as needed so they match the angle of the lower rail. (Dia. 6)
- Gently turn set screws just until cable is tight
- Make sure swages and tension blocks don't stick up over the top channel
- **TIP:** Tighten the rear set screws first, just until they reach the channel. Then tighten the front set screws. This helps to keep everything level. (Dia. 6)
- Use included hex bit to tighten tension block set screws in the sequence shown in Dia. 7
- Gradually tighten each tension block in the sequence shown in diagram until cable is straight and not easily bowed. Optional: Use a Loos Cable Tension Gauge to test cables near the center of the cables to reach the appropriate tensions. The recommended range on the PT-1 scale is 13~15 or 110-137 lbs using the Loos Cable Tension Gauge. **CAUTION: DO NOT OVER TIGHTEN SET SCREWS!**

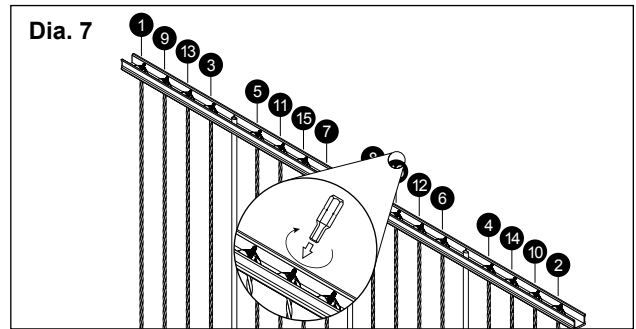
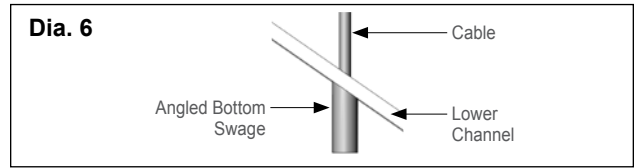
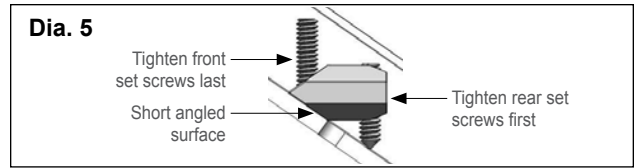

## 7 Cut and Install Top and Bottom Rail Snaps

- Following the same angle as the secured stair panel, clamp or hold top/bottom rail snaps against 3" posts (Dia. 8). Using a sharp #2 pencil, mark the top/bottom rail snaps at all four (4) locations
- Remove clamps and cut top/bottom rail snaps at all four (4) locations. Take care to cut snaps at appropriate stair angle. Use of Miter saw with a sharp non-ferrous blade is recommended. Cut 1/16" less than opening size
- Clean cut areas and apply touch-up paint on exposed ends
- Snap each rail snap over the corresponding rail channel until properly seated (Dia. 9). **TIP:** It may be necessary to temporarily support the lower channel when pushing down the top rail snap
- Install #8 x 1-1/2" self-tapping screws approximately 1-1/2" from the inside of the end posts as shown (both sides). (Dia 11)

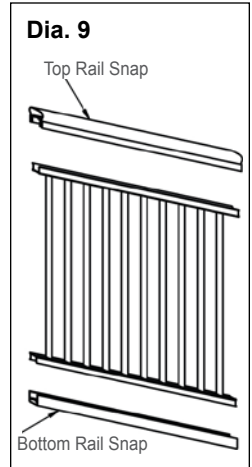
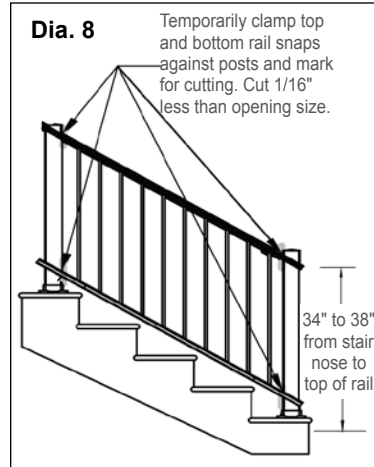

## 8 Install Post Caps and Base Plate Covers

## 9 Install ADA Compliant Hand Rail

ADA handrail may be required (Dia. 10) for residential deck installations (check with local building code official). Maximum recommended span between posts is 6' on center. See instructions at [railingaccents.com](http://railingaccents.com) for all installation configurations.

